



## Installation instructions

# Trim panels on models W/V 140 as of 5/94 88.09

The trim panels in the spare part scope of delivery are primed and can be painted in the vehicle color before installation in accordance with the brochure "Painting of vehicle components".

The installation instructions are divided up into the following sections:

1. AMG front apron
2. Side rocker panels
3. AMG rear apron
4. AMG emblem
5. Notes on painting
6. Parts ordering notes

### **Note**

On vehicles with Parktronic System (PTS) observe notes in service repair instructions no. 07 100 2089 "Electrical system I, model 140"

**Note**

In the Federal Republic of Germany the conversion must be accepted by a technical testing station for motor vehicles and be entered into the vehicle documents.

The sections of the installation instructions are divided up as follows:

**1. AMG front apron**

- A. Preparation
- B. Assembly of front apron
- C. Final assembly

**2. Side rocker panels**

- A. Preparation
- B. Final assembly

**3. AMG rear apron**

- A. Preparation
- B. Assembly of rear apron
- C. Final assembly

**4. AMG emblem**

- A. Attaching AMG emblem on trunk lid

**5. Information on painting****6. Parts ordering notes**

- A. Front apron
- B. Side rocker panels
- C. Rear apron

# 1. Front apron

## A. Preparation

1. Removing production bumper.
  - 1.1 Open covers (1) and remove from retainers. If an outdoor temperature display is fitted, remove outdoor temperature sensor with retaining element from the left cover. Unscrew nut (2), remove washer.
  - 1.2 Unscrew retaining brackets on sliding side catches.
  - 1.3 Pull bumper toward front.

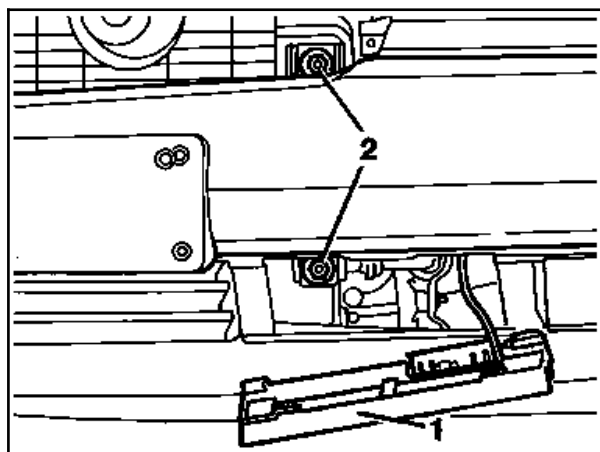

P88-5424-13

2. Disassembling bumper.
  - 2.1 Remove chrome trim:  
Pull off clips and remove chrome trim.Removing inner support:  
Loosen mounting bolts on left and right. Drill out rivets in sliding side catches. Press retaining tabs for outer covering out of retainers with screwdriver. Unscrew license plate cover and press out of retainers.

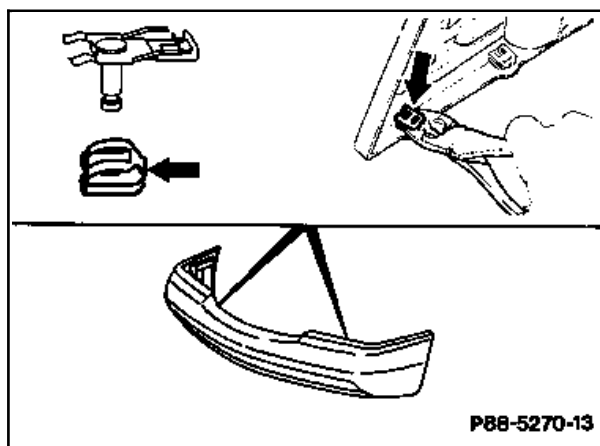

P88-5270-13

## B. Assembly

1. Installing inner support in AMG front apron:  
Insert inner support into AMG front apron and press into holding tabs. Screw in mounting bolts in left and right.
2. Installing chrome trim:  
Position chrome trim and secure from inside with clips.

## C. Final assembly

1. Position front apron, slide into side arresting devices and screw on loosely.
2. Check visually, align front apron as required (gap A = 5 mm) and tighten mounting nuts (2).
3. Reattach retaining bracket on sliding side catches.
4. Press license plate cover into recesses and secure with sheet metal screws.

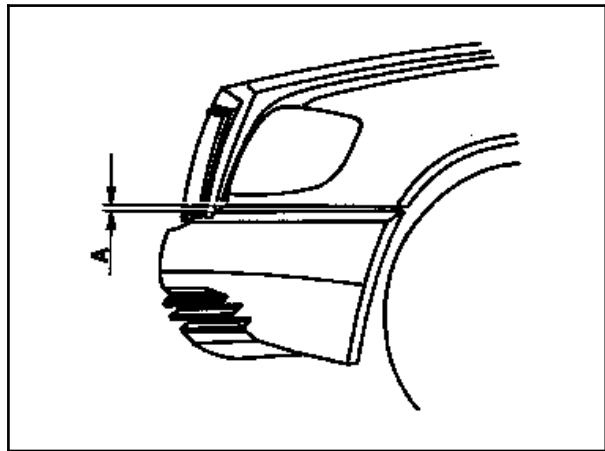

P88-0031-13

5. Installing cover (1).
- 5.1 On vehicles with outdoor temperature display press outdoor temperature sensor into recesses in left cover.

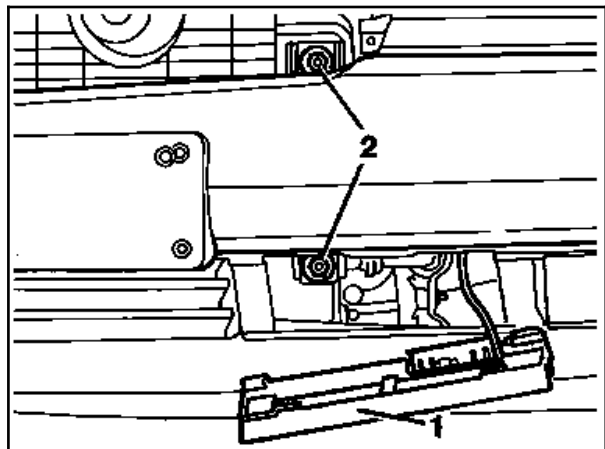

P88-5424-13

## 2. Side rocker panels

### A. Preparation

1. Remove side panels on front fender and rear wheelhouse.

1.1 Front side panel:

Loosen mounting nut (A) and mounting screw (B) on A-pillar. Using an assembly wedge, detach side panel at top from mounting elements and slide out of retainer on side rocker panel.

1.2 Rear side panel:

Using an assembly wedge, detach side panel at top and bottom from mounting elements and slide out of retainer on side rocker panel.

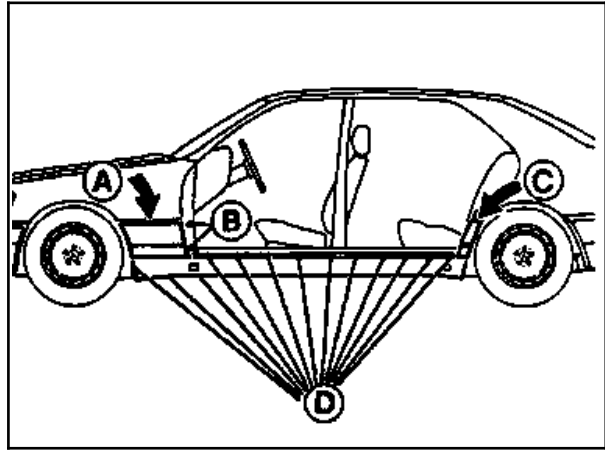

P88-5244-13

2. Pull side rocker panel rubber seal out of retaining slots.

Unscrew top and bottom mounting screws of rocker panel (D). Detach rocker panel from mounting elements with assembly wedge. Press mounting clips out of side rocker panel. Pull out retaining strap for jacking point cover.

## B. Final assembly

1. Mounting AMG side rocker panel.

1.1 Press mounting clips into the AMG side rocker panel.

1.2 Push in retaining strap for jacking point cover.

1.3 Position side rocker panel and screw on with standard mounting screws.

1.4 On vehicles **without stationary heater**:

Hook retaining bracket onto console for subframe. Screw side rocker panel and wheelhouse inner panelling to retaining bracket (A).

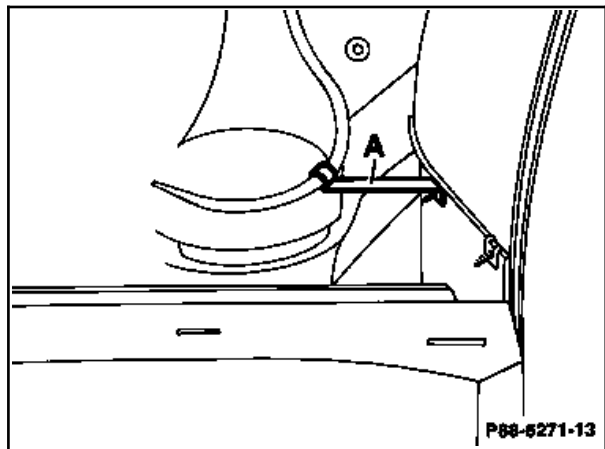

P88-5271-13

1.4 On vehicles **with stationary heater** on right side:

Loosen mounting screws (A), insert bracket (B) and tighten mounting screws.

Screw side rocker panel and wheelhouse inner panelling to retaining bracket.

1.5 Secure or screw rubber seal and side panels in mounting elements.

1.6 Push retaining strap into jacking point covers. The standard front covers are used, the rear covers are AMG parts.

Push covers into side rocker panel.

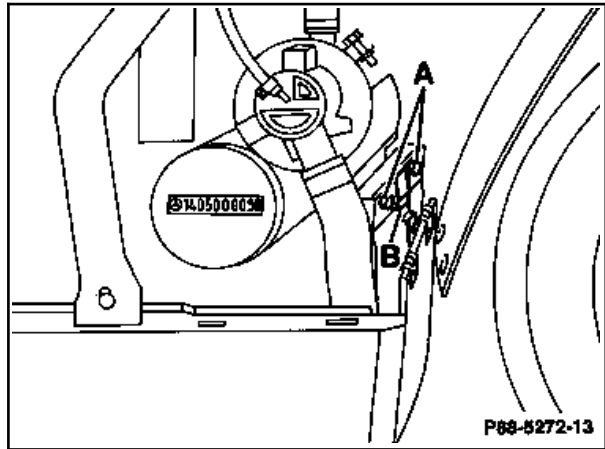

P88-5272-13

## 3. Rear apron

### A. Preparation

1. Removing bumper.

1.1 Open lamp unit and remove spreading rivets.

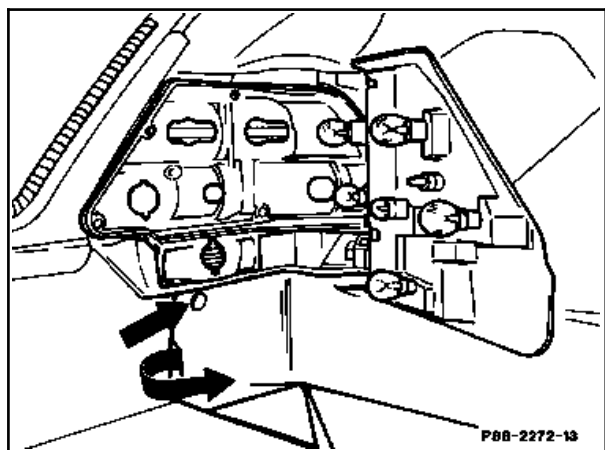

P88-2272-13

1.2 Remove expanding rivets for interior panelling.

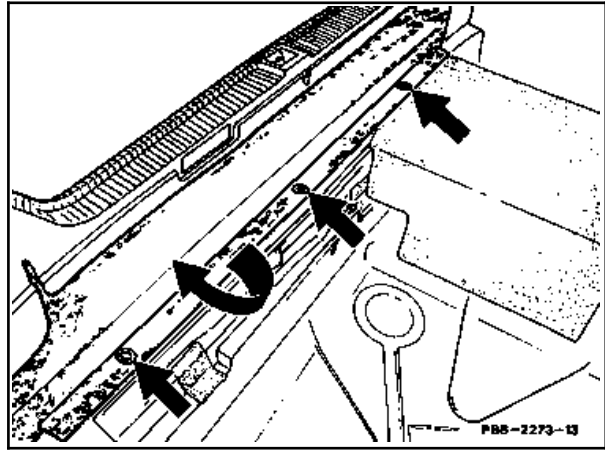

P88-2273-13

1.3 Press panelling to one side or upwards and unscrew mounting nuts and remove washers (6 off).

1.4 Pull bumper off toward rear.

2. Disassembling bumper.

2.1 Removing chrome trim:  
Pull off clips and lift off chrome trim.

2.2 Removing inner support:  
Loosen mounting screws on left and right.  
Pull off the two clips in the bottom cross member and pull out bolts. Drill out rivets on sliding side catches.

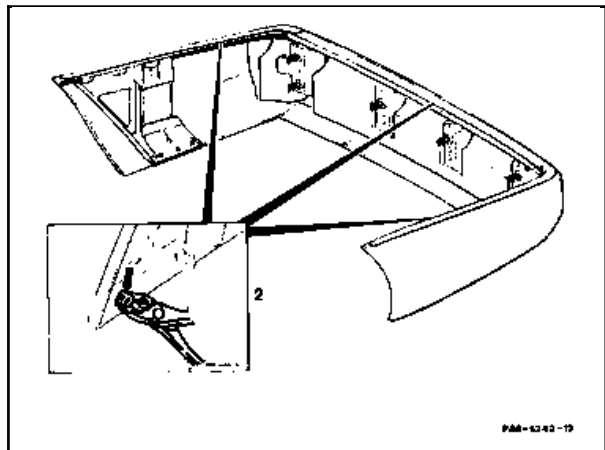

P88-5242-13

2.3 Press retaining tabs for outer covering out of retainers with screwdriver.

## B. Assembly

1. Installing standard inner support in AMG rear apron:

1.1 Insert inner support into AMG rear apron.

1.2 Press retaining tabs into mounts at top and bottom.

1.3 Screw in mounting screws at left and right.

1.4 Insert the two bolts into the bottom cross member and secure with clips.

1.5 Fasten sliding side catches with screws provided.

1.6  
Install chrome trim and secure with clips.

## C. Final assembly

1. Position rear apron, slide into sliding side catches and screw on loosely.
2. Check visually, if necessary align rear apron (gap A = 5 mm) and tighten mounting nuts.
3. Install inner panelling and lamp units.

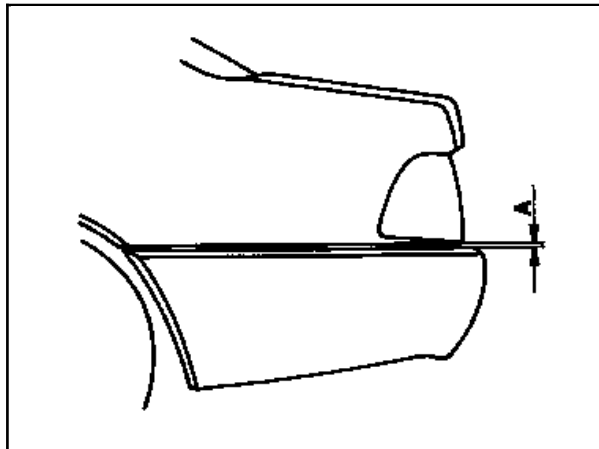

P88-0030-13

## 4. AMG emblem

1. Attaching AMG emblem on trunk lid:
  - 1.1 Heat AMG emblem and gluing surface on trunk lid to approx. 40 °C (radiant heater, hot air gun, etc.).

1.2 Position AMG emblem according to drawing and press on firmly.

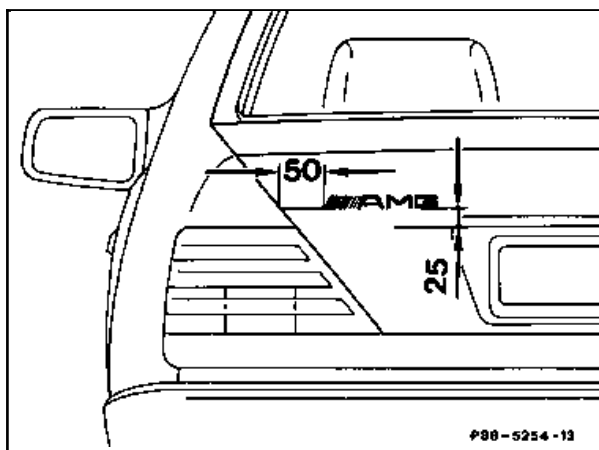

P88-5254-13

## 5. Notes on painting



Refer to chapter  
**"Painting specifications and  
 recommendations for repairing plastic  
 parts"**

## 6. Parts ordering notes

The parts required for installation can be obtained under the following part numbers:

### A. Front apron without PTS

Quantity	Designation	Part no.
	Complete front apron, comprising:	B6 602 07 40
1	Front apron	H WA140 885 04 25
1	Left cover	H WA140 885 05 26
1	Right cover	H WA140 885 06 26
8	Nut	A126 990 03 54
8	Washer	N009 021 005 202
8	Screw	N000 965 005 014

### A. Front apron with PTS

Quantity	Designation	Part no.
	Complete front apron, comprising:	B6 602 07 41
1	Front apron	H WA140 885 06 25
1	Left cover	H WA140 885 05 26
1	Right cover	H WA140 885 06 26
8	Nut	A126 990 03 54
8	Washer	N009 021 005 202
8	Screw	N000 965 005 014

### B. Side rocker panels

Quantity	Designation	Part no.
	Complete side rocker panel, comprising:	B6 602 07 45
1	Left panel (V140)	H WA140 698 09 54
1	Right panel (V140)	H WA140 698 10 54
1	Left rear cover	H WA140 698 02 30
1	Right rear cover	H WA140 698 03 30
2	Bracket	H WA140 690 01 14
1	Bracket	H WA140 690 02 14
	Complete side rocker panel, comprising:	B6 602 07 44
1	Left panel (W140)	H WA140 698 07 54

1	Right panel (W140)	H WA140 698 08 54
1	Left rear cover	H WA140 698 02 30
1	Right rear cover	H WA140 698 03 30
2	Bracket	H WA140 690 01 14
1	Bracket	H WA140 690 02 14

### C. Rear apron without PTS

Quantity	Designation	Part no.
	Complete rear apron, comprising:	B6 602 07 42
1	Rear apron	H WA140 885 05 25
8	Nut	A126 990 03 51
4	Screw	N000 933 005 075
8	Washer	N009 021 005 202
4	Screw	N000 965 005 014

### C. Rear apron with PTS

Quantity	Designation	Part no.
	Complete rear apron, comprising:	B6 602 07 43
1	Rear apron	H WA140 885 07 25
8	Nut	A126 990 03 51
4	Screw	N000 933 005 075
8	Washer	N009 021 005 202
4	Screw	N000 965 005 014