

## Crankshaft, removing and installing

### Note:

When working on the engine, it should be secured to the engine stand using the engine bracket VW 540 ⇒ [Page 10-27](#).

### 1 - Bearing shell

- ◆ For cylinder block with oil groove
- ◆ Do not interchange used bearing shells (mark).
- ◆ Install new bearing plates for cylinder block with the correct color coding ⇒ Fig. ⇒ [2](#), ⇒ [Page 13-72](#)

### 2 - Chain sprocket

- ◆ For oil pump drive chain
- ◆ Replacing ⇒ [Page 13-77](#)

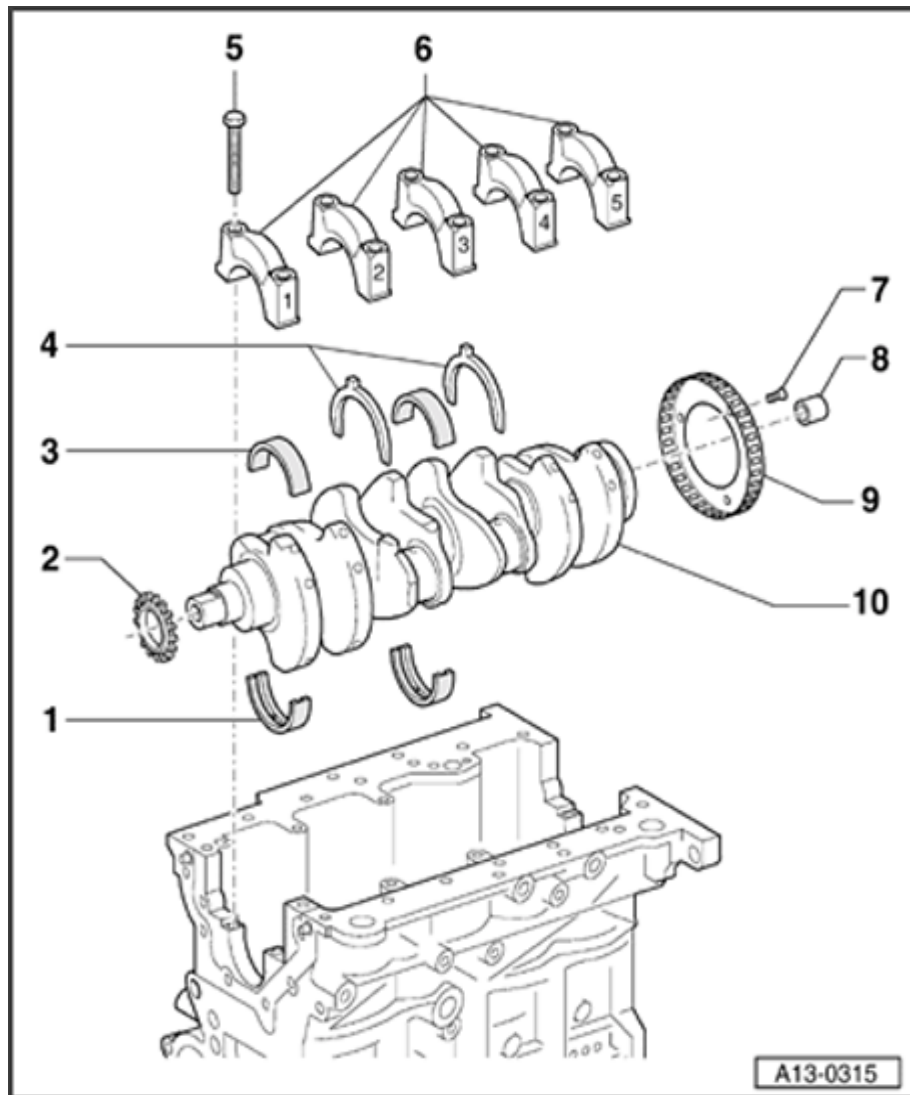

### 3 - Bearing shell

- ◆ For bearing cap without oil groove
- ◆ Do not interchange used bearing shells (mark).
- ◆ The crankshaft bearing plates in the bearing covers are supplied as spare part with the color coding "yellow"

### 4 - Thrust washers

- ◆ For bearing 3
- ◆ Different types for cylinder block and bearing cap
- ◆ Note locating arrangement

### 5 - 65 Nm + $\frac{1}{4}$ turn (90°) further

- ◆ Always replace
- ◆ When measuring radial clearance of crankshaft, tighten to 65 Nm but do not turn further.

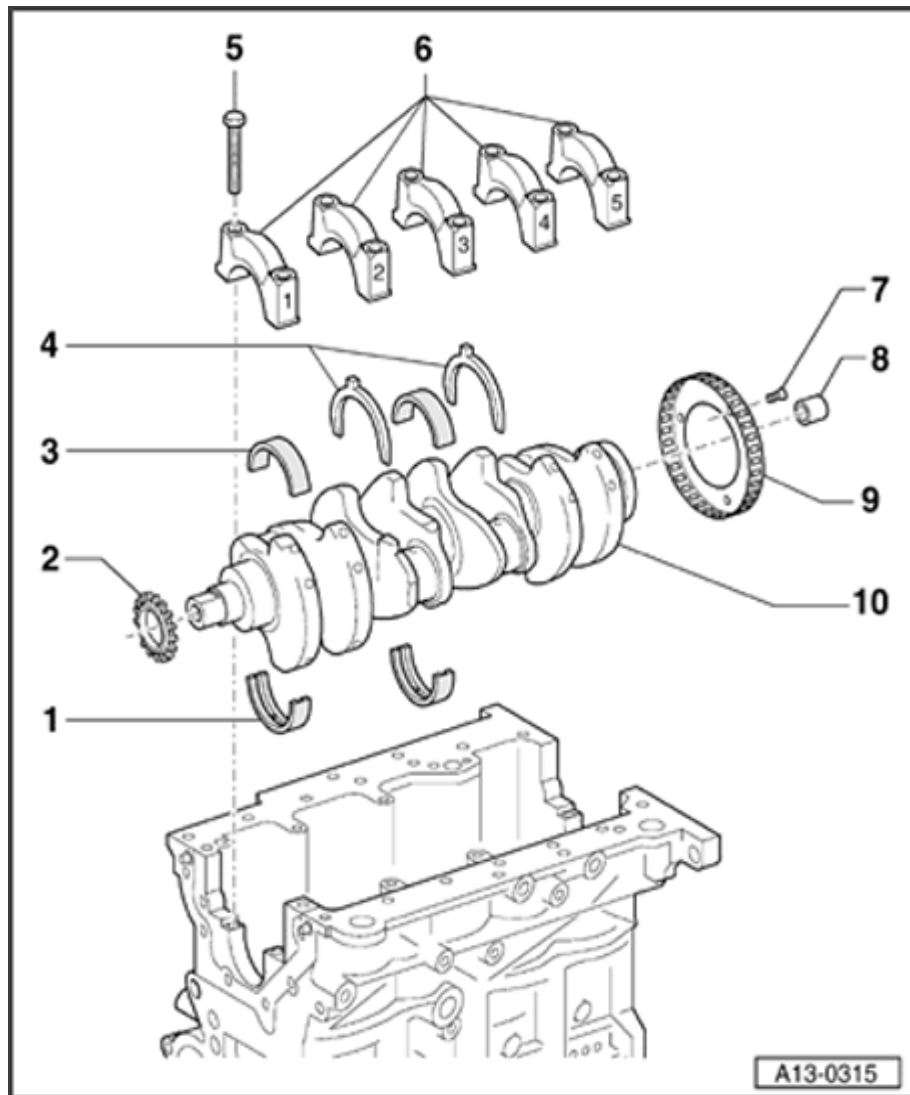

### 6 - Bearing cap

- ◆ Bearing cap 1: Pulley end
- ◆ Bearing cap 3 with recesses for thrust washers
- ◆ Bearing shell retaining lugs (cylinder block/bearing cap) must be on the same side

### 7 - 10 Nm + $\frac{1}{4}$ turn (90°) further

- ◆ Always replace
- ◆ After each removal of the bolts replace sensor wheel ⇒ Fig. ⇒ [1](#), ⇒ [Page 13-71](#)

### 8 - Needle bearing

- ◆ For vehicles with manual transmission
- ◆ Pulling out and driving in ⇒ [Page 13-73](#)

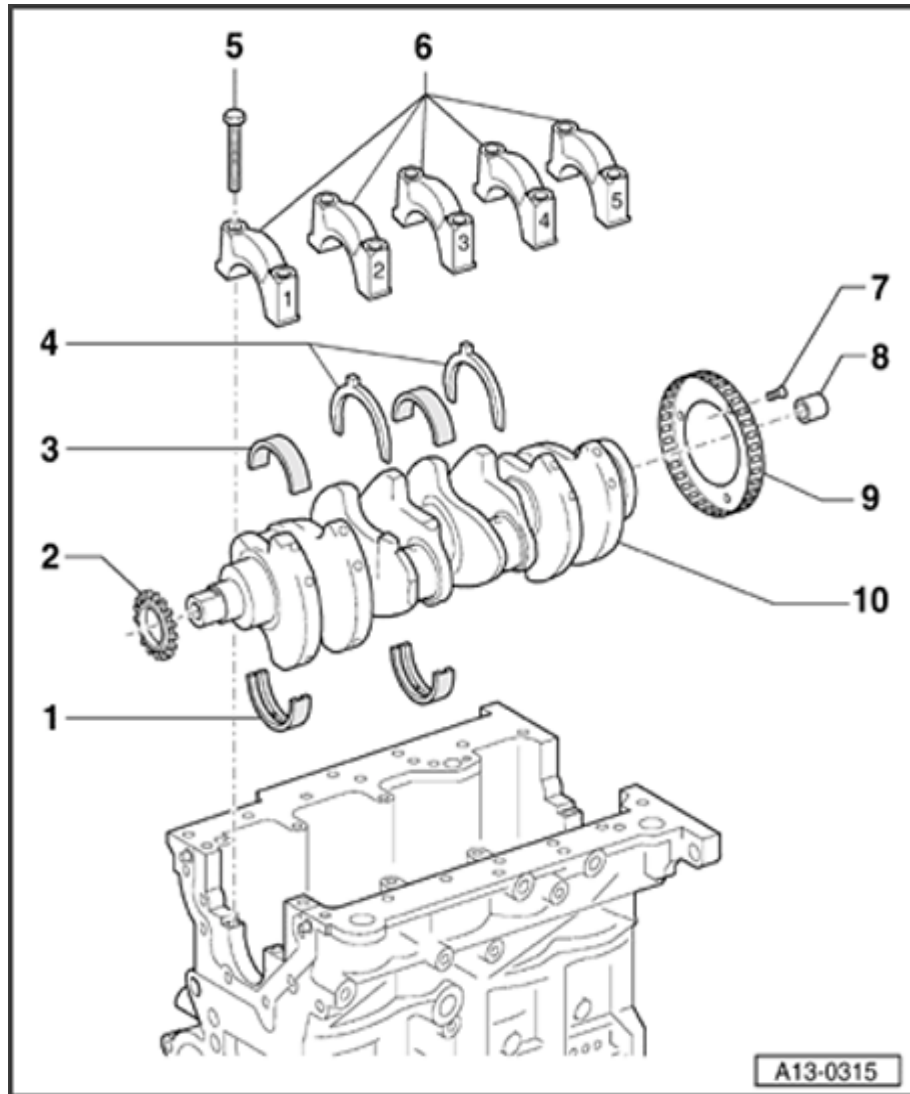

### 9 - Sensor wheel

- ◆ For engine speed sensor -G28-
- ◆ Can only be installed in one position. Holes are offset
- ◆ Always replace sensor wheel if securing bolts have been loosened.
- ◆ Removing and installing ⇒ Fig. ⇒ [1](#) , ⇒ [Page 13-71](#)

### 10 - Crankshaft

- ◆ Axial clearance new: 0.07 to 00.23 mm, Wear limit: 0.30 mm
- ◆ Check radial clearance with Plastigage™ , New: 0.02 to 0.04 mm, Wear limit: 0.15 mm
- ◆ Do not rotate the crankshaft when checking the radial clearance.
- ◆ Crankshaft dimensions ⇒ [Page 13-76](#)

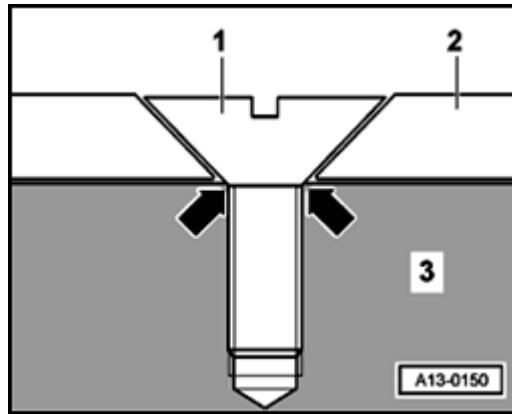

A

**Fig. 1 Removing and installing sensor wheel**

**Note:**

- ◆ *Always replace sensor wheel -2- if securing bolts -1- have been loosened..*
- ◆ *If the securing bolts are tightened a second time, the seats for the countersunk bolt heads in the sensor wheel will be distorted to such an extent that the bolt heads will come into direct contact with the crankshaft -3- (-arrows-) and the sensor wheel will only fit loosely under the bolts.*
- ◆ *The mounting holes are asymmetrically spaced, so it is only possible to install the sensor wheel in one position.*

**Tightening torque**

Component	Nm
Sensor wheel to crankshaft	10 + 90 ° 1)2)

1) Replace bolts

2) 90 ° corresponds to a quarter turn

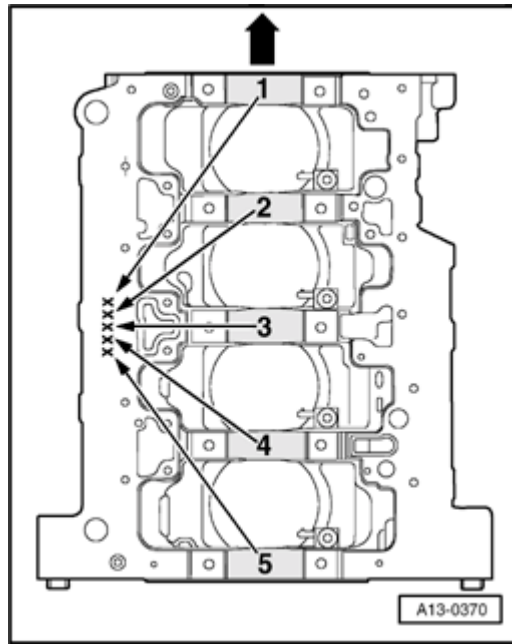

A

**Fig. 2 Allocation of crankshaft bearing plates for cylinder block**

The bearing plates with the correct thickness are allocated to the cylinder block at the factory. Colored dots are used to mark the thickness of the bearing plates.

**Note:**

*Arrow points in direction of travel.*

The position of each bearing thickness is marked with letters on the lower sealing area of the cylinder block.

Letter on cylinder block		Color of bearing
S	=	Black
R	=	Red
G	=	Yellow

**Note:**

*The crankshaft bearing cups in the bearing covers are supplied as spare part with the color coding "yellow".*

## Crankshaft needle bearing, removing and installing

### Special tools and equipment

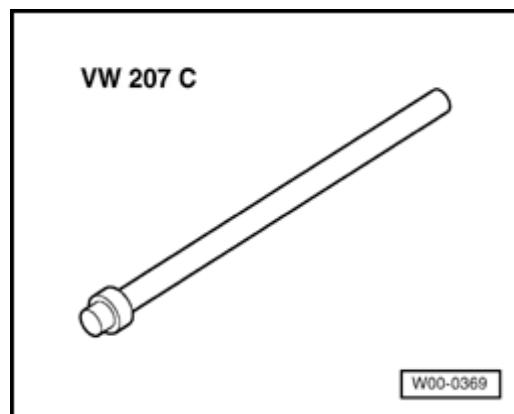

A

- ◆ Special tool VW 207 C

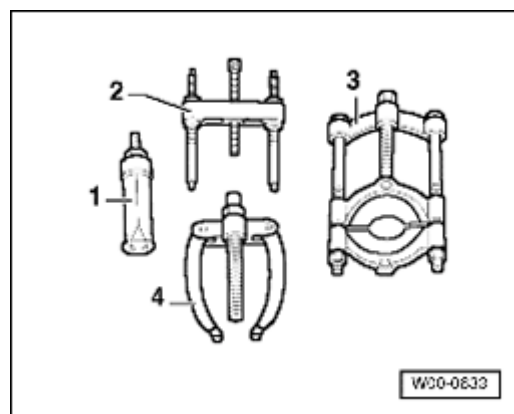

A

- ◆ Special tool Kukko 21/1 (Item 1) and Kukko 22/1 (Item 4)
- ◆ Depth gauge

**Note:**

- ◆ *A needle bearing must be installed in the crankshaft on vehicles with a manual transmission. Install needle bearing if necessary.*
  
- ◆ *The needle bearing must not be installed in the crankshaft on vehicles with an automatic transmission. Remove needle bearing if necessary.*

**Removing****A**

- Pull out needle bearing with Kukko 21/1 and Kukko 22/1.

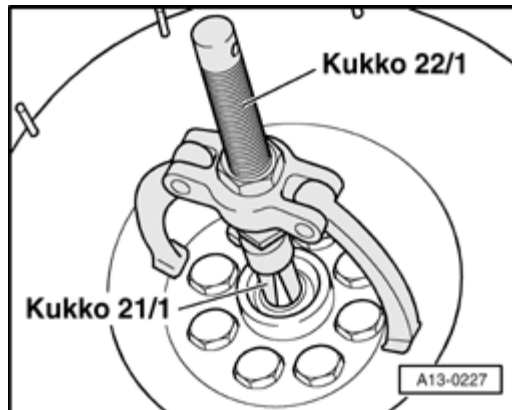



13-75

### Installing

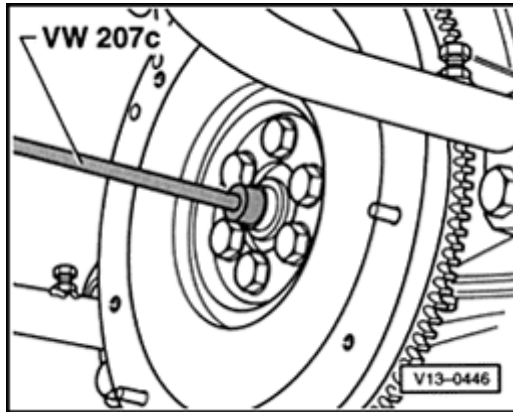

- A - Drive in using 207c or centralizing pin 3176.
  - ◆ Lettering on needle bearing must be visible when installed

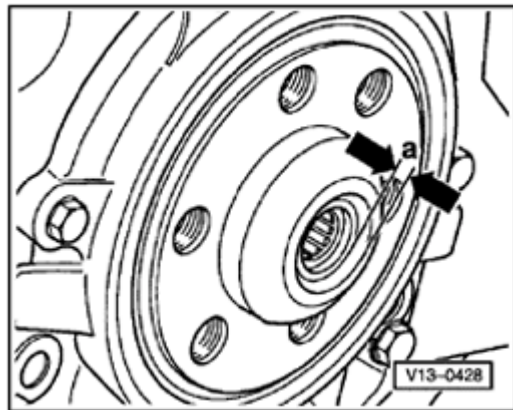

- A - Installation depth of needle bearing
  - ◆ Distance a = 1.5 mm

## Crankshaft dimensions

(in mm)

Honing dimension	Crankshaft bearing		Conrod journal	
	main journal diameter		main journal diameter	
		-0.017		-0.022
Basic dimension		54.00		47.80
		-0.037		-0.042
		-0.017		-0.022
1st undersize		53.75		47.55
		-0.037		-0.042
		-0.017		-0.022
2nd undersize		53.50		47.30
		-0.037		-0.042
		-0.017		-0.022
3rd undersize		53.25		47.05
		-0.037		-0.042

## Chain sprocket, removing and installing

### Special tools and equipment

- A
- ◆ Sleeve 30-100
  - ◆ Two-arm puller, commercially available.
  - ◆ Protective gloves

### Removing

- Remove oil pan ⇒ [Page 17-11](#) .
  - Removing front sealing flange ⇒ [Page 13-56](#) .
  - Disconnect chain wheel of oil pump, remove chain tensioner and chain ⇒ -Item 5 -, ⇒ [Page 17-3](#) .
- A
- Pull chain sprocket off crankshaft with puller -2- (Use a suitable washer -1- to protect end of crankshaft).

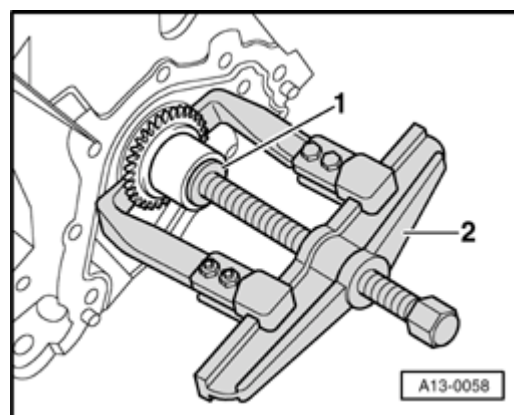
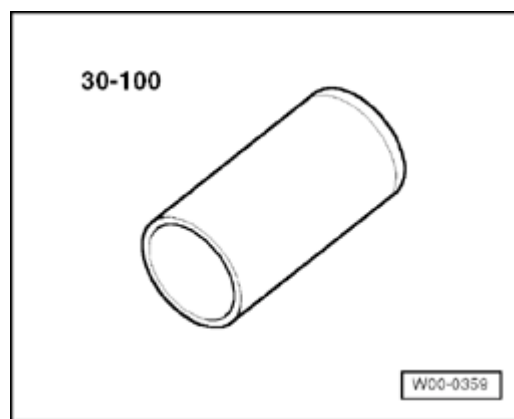

## Installing

Installation is carried out in the reverse order of removal; note the following:

### **WARNING!**

### ***Wear protective gloves!***

- Heat chain sprocket in heating appliance for approx. 15 minutes to 220 ° C.

### **Note:**

*Installation position: wide collar on sprocket facing toward engine*

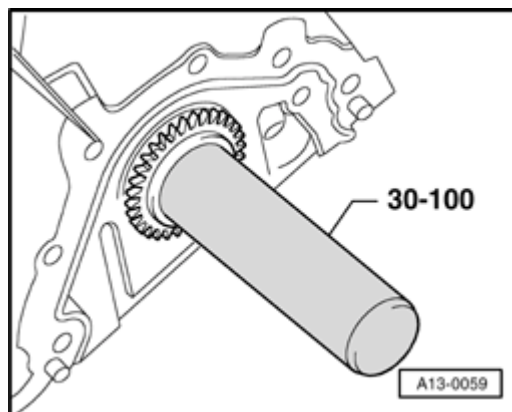

**A**

- Install chain sprocket on end of crankshaft using pliers and push onto seat on crankshaft with drift sleeve 30-100.